



COUNTY OF SAN JOAQUIN

DEPARTMENT OF PUBLIC WORKS
P.O. BOX 1810-1810 E. HAZELTON AVENUE
STOCKTON, CALIFORNIA 95201
(209) 468-3000
FAX # (209) 468-9324

Permit No: PS-1801879
Date Issued: 05/22/2018
Start Date: 05/22/2018
Exp. Date: 06/15/2018
Project No: PWP730052
Quad: SE

UE/CR/PM NO:31205564

ENCROACHMENT PERMIT

To: PACIFIC GAS & ELECTRIC - STOCKTON
PO BOX 930
STOCKTON, CA 95201

Encroachment Type:

Bell Hole			
-----------	--	--	--

Location:

E/S OF HENRY RD. 170' S/O HALL RD.

In compliance with your request of 05/22/2018 , permission is hereby granted to do work in County right-of-way as shown on attached application and subject to all the terms, conditions and restrictions written below or printed as general or special provisions on any part of this form. See reverse side and attached sheet, if any.

Trench excavations for service connections will not be permitted within ten feet (10') of pavement centerline unless otherwise approved by the Director. Surface of trench patches shall match in kind and be smooth and even with that of abutting surface. Special attention shall be given to depth of utilities through roadside area in anticipation of future drainage facilities, road profile and/or frontage development. All underground utility facilities are to be established and accurately dimensioned on sketches from surveyed centerline of road right of way, or from right of way (border) lines.

Permittee shall call the Department of Public Works, Field Engineering Division (Permit Inspections) at (209)953-7421 at least forty-eight hours prior to beginning any work within the County right of way. All work performed under this permit shall conform to the rules and regulations pertaining to safety established by the California Division of Industrial Safety and Cal-OSHA.

The jobsite shall be kept in a safe condition at all times by the daily removal of any excess dirt or debris which might be a hazard to either pedestrian or automobile traffic. All necessary traffic convenience and warning devices and personnel shall be provided, placed and maintained by and at the sole expense of the Permittee in accordance with the latest edition of the CALTRANS Manual of Traffic Control.

After completion of the work permitted herein, all debris, lumber, barricades, or any excess material shall be removed and the jobsite left in a neat workmanlike manner. Immediately following completion of construction permitted herein, Permittee shall fill out and mail notice of completion (see attached post card) provided by Grantor.

Special Comments:

Traffic Control Per MUTCD****See Attached "Special Conditions"*****

FORMS:

SS/WW, R-29		
-------------	--	--

Est. Permit Fee: \$436.00

- WHITE -Permittee
- GOLDENROD -PWD Central File
- YELLOW -Field Inspection
- PINK -Permit Section

KRIS BALAJI, Director
Department of Public Works

By: 
Permit Section

ENCROACHMENT PERMIT GENERAL PROVISIONS

13-1

1. This permit is issued under and subject to all laws and ordinances of agencies governing the encroachment herein permitted. See the following references:
STREETS AND HIGHWAYS CODE
 1. Division 1, Chapter 3
 2. Division 2, Chapter 2, Section 942
 3. Division 2, Chapter 4, Section 1126
 4. Division 2, Chapter 5.5 and Chapter 6
SAN JOAQUIN COUNTY ORDINANCES NUMBERED: 324, 441, 648, 662, 672, 695, 700, 860, 892, 3359, and 3675.
2. It is understood and agreed by the Permittee that the performance of any work under this permit shall constitute an acceptance of all the provisions contained herein and failure on the Permittee's part to comply with any provision will be cause for revocation of this permit. Except as otherwise provided for public agencies and franchise holders, this permit is revocable on five days notice.
3. All work shall be done subject to the supervision of and the satisfaction of the grantor. The Permittee shall at all times during the progress of the work keep the County Highway in as neat and clean condition as is possible and upon completion of the work authorized herein, shall leave the County Highway in a thoroughly neat, clean and usable condition.
4. The Permittee also agrees by the acceptance of this permit to properly maintain any encroachment structure placed by the Permittee on any part of the County Highway and to immediately repair any damage to any portion of the highway, which occurs as a result of the maintenance of the said encroachment structure, until such time as the Permittee may be relieved of the responsibility for such maintenance by the County of San Joaquin.
5. The Permittee also agrees by the acceptance of this permit to make, at its own expense, such repairs as may be deemed necessary by the County Department of Public Works.
6. It is further agreed by the Permittee that whenever construction, reconstruction or maintenance work upon the highway is necessary, the installation provided for herein shall, upon request of the County Department of Public Works, be immediately moved or removed by and at the sole expense of the Permittee.
7. No material used for fill or backfill in the construction of the encroachment shall be borrowed or taken from within the County right of way.
8. All work shall be planned and carried out with as little inconvenience as possible to the traveling public. No material shall be stacked within eight feet (8') of the edge of the pavement or traveled way unless otherwise provided herein. Adequate provision shall be made for the protection of the traveling public. Traffic control standards shall be utilized including barricades; approved signs and lights; and flagmen, as required by the particular work in progress.
9. The Permittee, by the acceptance of this permit, shall assume full responsibility for all liability for personal injury or damage to property which may arise out of the work herein permitted or which may arise out of the failure of the part of the Permittee to properly perform the work provided under this permit. In the event any claim of such liability is made against the County of San Joaquin or any department, official or employee thereof, the Permittee shall defend, indemnify, and hold each of them harmless for such claim.
10. All backfill material is to be moistened as necessary and thoroughly compacted with mechanical means. If required by the County Director of Public Works, such backfill shall consist of gravel or crushed rock. The Permittee shall maintain the surface over structures placed hereunder as may be necessary to insure the return of the roadway to a completely stable condition and until relieved of such responsibility by the County Department of Public Works. Wherever a gravel, crushed rock or asphalt surface is removed or damaged in the course of work related to the permitted encroachment, such material shall either be separately stored and replaced in the roadway as nearly as possible in its original state or shall be replaced in kind, and the roadway shall be left in at least as good a condition as it was before the commencement of operations of placing the encroachment structure.
11. Whenever it becomes necessary to secure permission from abutting property owners for the proposed work, such authority must be secured by the Permittee prior to starting work.
12. The current and future safety and convenience of the traveling public shall be given every consideration in the location and methods of construction utilized.
13. The Permittee is responsible for the preservation of survey monuments located within the area of work herein permitted. Prior to the start of construction, survey monuments that potentially may be disturbed shall be located and referenced by a Licensed Land Surveyor, and a Corner Record filed with the County Surveyor. Any Survey Monuments disturbed during the course of construction shall be reestablished by a Licensed Land Surveyor and another Corner Record filed with the County Surveyor. (Land Surveyors' Act Section 8771)
14. Prior to any excavation, the Permittee shall notify USA North (Underground Service Alert of Northern California and Nevada) at 811 or 800-227-2600 forty-eight (48) hours in advance.

SPECIAL CONDITIONS FOR
PG&E – PM 31205564
ENCROACHMENT PERMIT

1. Maintain traffic controls for all roads. Traffic control delays shall not exceed 15 minutes. Two-way traffic shall be maintained during non-working hours with excavated areas backfilled or plated. During working hours, two-way traffic control shall be maintained with one lane open and appropriate flaggers.
2. Access to all properties shall be maintained at all times except when work is occurring at the access point. Minimal delays will be allowed to provide access within the work zone area. Driveway access shall be fully restored at the end of each workday. Driveways disturbed by the contractor shall be replaced with in-kind or better materials.
3. Residents and businesses shall be notified in writing, as approved by the County, 48 hours in advance of any impacts to their access.
4. Any areas where parking is to be restricted shall have signs noting the restrictions in place at least 48 hours in advance.
5. School Buses shall be passed through the work zone with minimal delays.
6. All destroyed or obliterated pavement markings must be replaced in kind by the permittee. Typical pavement markings include but not limited to lane lines, centerlines, stop and stop ahead legends, limit lines, raised pavement markers and miscellaneous delineators.
7. The Permittee is responsible for the preservation of survey monuments located within the area of work herein permitted. Prior to the start of construction, survey monuments that potentially may be disturbed shall be located and referenced by a Licensed Land Surveyor, and a Corner Record filed with the County Surveyor. Any Survey Monuments disturbed during the course of construction shall be reestablished by a Licensed Land Surveyor and another Corner Record filed with the County Surveyor. (Land Surveyors' Act Section 8771)
8. All pipe and pipeline related facilities including, but not limited to, valves, utility boxes and vaults, and frames and covers shall be maintained by PG&E, including any facilities that are abandoned in place. PG&E shall be responsible for any and all costs associated with the removal, relocation and/or adjustment of these facilities as determined by the County at PG&E's expense. (Streets and Highways Code Section 1463)
9. All future maintenance of the pipeline and related facilities within the County right-of-way will require a San Joaquin County Encroachment Permit.
10. Bell holes shall be maintained in a smooth and even condition to the satisfaction of the County throughout the project limits at all times.
11. All bell holes shall be completely backfilled or shored and plated at the end of each workday, and the roadway restored to two-way traffic. If plating is to be used, a trench shoring and plating plan suitable for traffic loadings shall be prepared by a registered civil engineer and submitted for prior approval by the County.

12. The contractor shall use San Joaquin County Improvement Standard R-29 when backfilling trenches within the County right-of-way. Where the existing road structural section is below standard, a minimum section of 3 inches of asphalt concrete over 8 inches of aggregate base shall be required.
13. County roads shall be kept clean from mud and debris at all times along the access points and work zone areas during entire project. All standard roadway striping and signage shall be clearly visible, maintained and restored throughout the construction zone during and after the project.
14. In addition to standard dust control measures, streets shall be maintained in a clean condition, free of dirt, mud and debris during construction activities. The contractor shall provide daily, or as needed, street sweeping using a modern mechanical or vacuum-assisted street sweeper.
15. The contractor shall not conduct construction operations in rain or heavy fog conditions.

RECEIVED
SAN JOAQUIN COUNTY
2018 MAY -3 AM 11:08

APPLICATION FOR ENCROACHMENT PERMIT

PLEASE PRINT:

Date 5/3/2018

To: San Joaquin County
Department of Public Works

PG&E **PM 31205564**

(Applicant Name)

4040 West Lane

(Mailing Address)

Stockton, CA 95204

(City, State, Zip Code)

290-470-2300

(Area Code - Telephone Number)

S6PZ@pge.com

(Email Address)

OFFICE USE ONLY DEPT. OF PUBLIC WORKS

JOB #	<u>730052-6</u>	REF #	
APN		CR #	
EXP. DATE	<u>6/15/18</u>		
VALID	<u>5/22/18</u> TO <u>6/15/18</u>	DRIVEWAYS:	
STREET	<u>Henry Rd.</u>	*	
AREA	<u>Escalon</u> QUAD <u>SE</u>	*	
TYPE	<u>Bell Hole, Test Station Install</u>		
FORMS	<u>SS/WW, R-29, Special Conditions</u>		
NOTES			

Sketch (Detailed plans may be submitted)

See attached - refer to UID 27036.

Crew to call SJ County Inspector at 209-953-7421 48 to 72 hours before work starts.

The undersigned hereby applies for permission to excavate, construct and/or otherwise encroach on County Highway Right-of-Way on the east side of Henry Rd approximately 170 feet/mile SOUTH of Hall Rd, by performing the following work (description of work):

Traffic control, 4'x4' bell hole, test station installation, backfill and restoration

COUPON TEST STATION WILL REMAIN 3' TO 4'

ABOVE GRADE

Work will commence on or after 5/21/18 for approximately 2 days.

I, the undersigned, certify that I am the owner of the respective property, or am qualified to represent the owner and agree to do the work described above in accordance with the rules and regulations of San Joaquin County and subject to inspection and approval.

Sam Robee Permit Facilitator
Signature of Applicant - Title

5/3/2018

Date

UID 27036

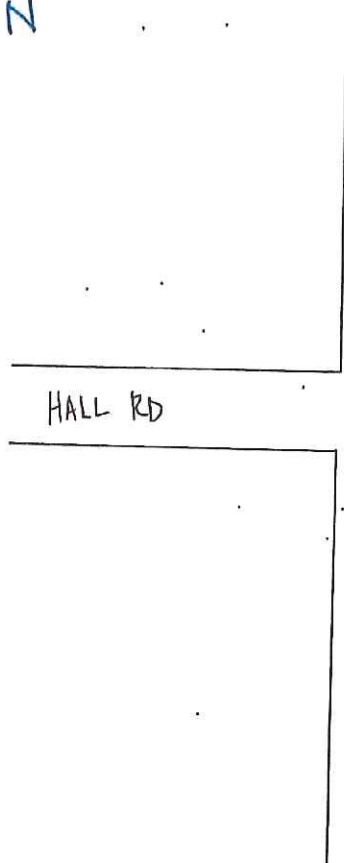

HENRY RD

HALL RD

170'

5'

16'

Row

Row

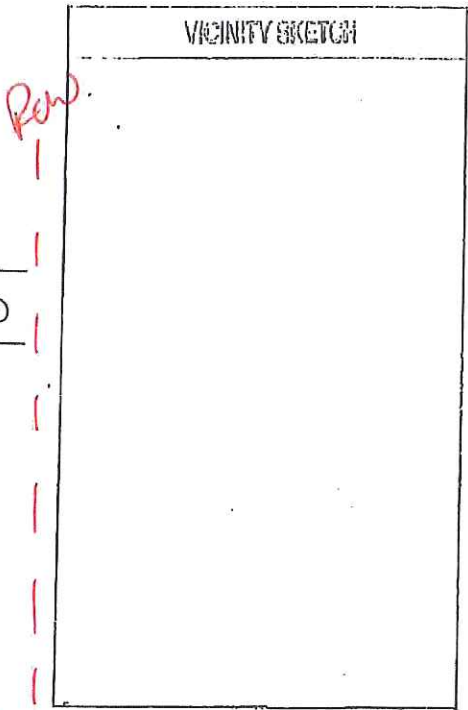

VICINITY SKETCH

20' x 80' STAGING AREA

4' x 4' BELL HOLE (8' DEEP) APPROX

GAS MAIN

EP

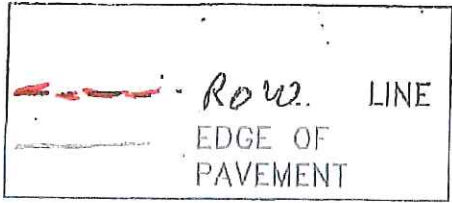

Row. LINE

EDGE OF PAVEMENT

EST:	
ADP:	
SUPV:	
REP:	
PLNR:	
SCALE:	DATE:

PERMIT SKETCH

CO:	
SD:	
NOTIF:	
OTHER:	
SHT: 1 OF 1	SHEETS



PACIFIC GAS AND ELECTRIC COMPANY

31205564

REV.

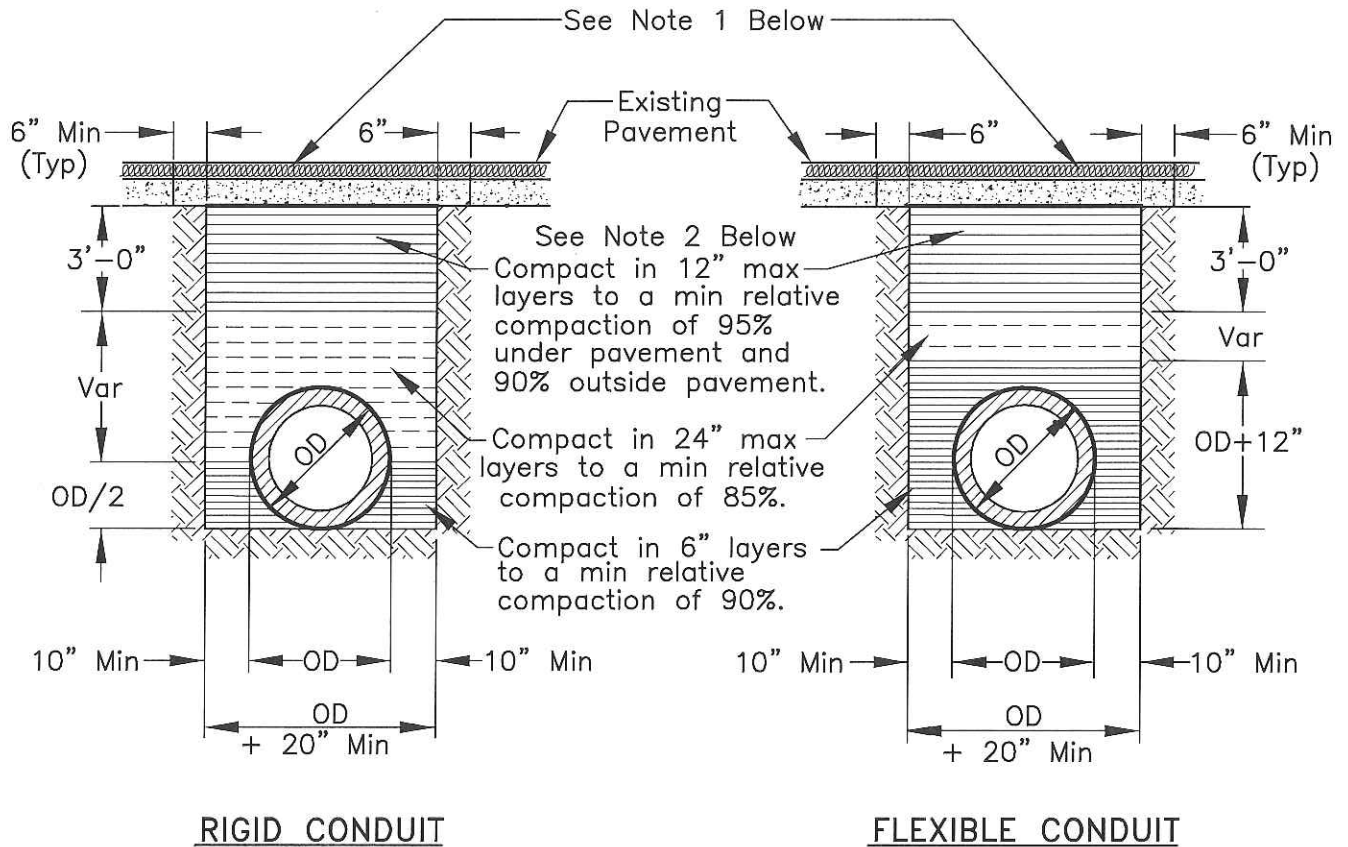

NOTES:

1. New pavement shall be 1" thicker than existing pavement, minimum of 0.25 Ft. New base shall be 1" thicker than existing base, min of 0.50 Ft.
2. Select native material or imported granular material as approved by the Director of Public Works. Backfill with materials equal to or better than the existing pavement and base in quality.
3. Relative compaction of materials shall be tested in accordance with the State of California, Dept. of Transportation Testing Manuals, test method No. California 216 or 231.
4. All existing pavement shall be neatly cut to line prior to trench excavation.
5. Jetting or ponding will be permitted within the street right-of-way with a 3 year bond, when approved by the Director of Public Works.
6. When shown by soil composition and compactability, ninety percent (90%) compaction may be used, when approved by the Director of Public Works.
7. Special bedding and backfill requirements may be shown on the plans or specified in the special provisions.

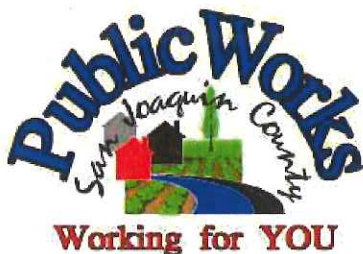

TYPICAL TRENCH BACKFILL

COUNTY OF SAN JOAQUIN
DEPARTMENT OF PUBLIC WORKS

Date: DEC 2014

Approved by:

Thomas M. Hall

No.	Revision	Description	Date

Std. Dwg. No.

R-29

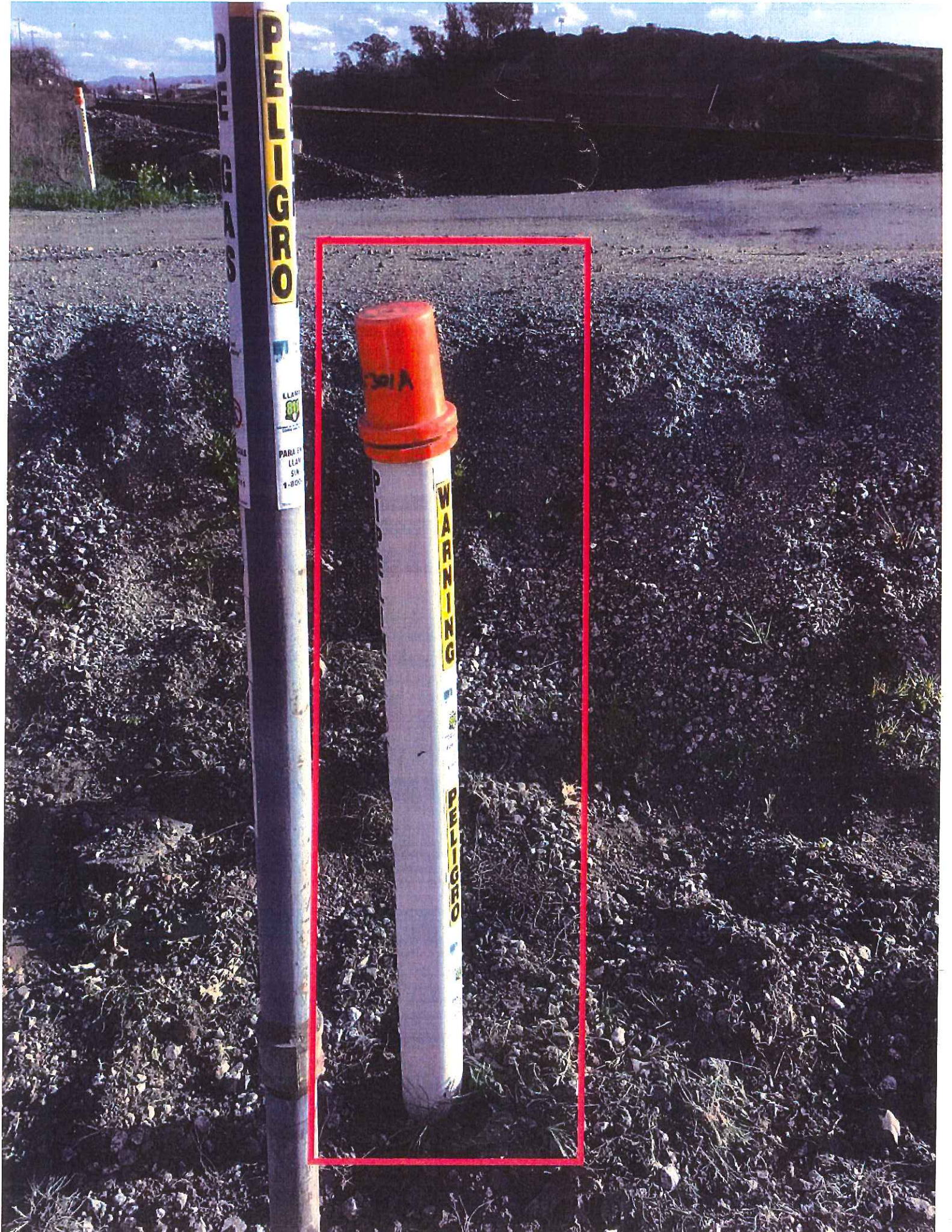

PELIGRO

PARA EN LLENAR SIN 9-800

WARNING

CC Technologies CS-3100 Coupon Test Station



CS-3100 - 10 feet Long Coupon Test Station

An accurate, inexpensive, and easily installed alternative for monitoring the effectiveness of cathodic protection on pipelines and other underground structures.

Design is based on continuing research for Pipeline Research Committee (PRC) International.

Installation in an augured hole minimizes soil disturbance and allows the rapid (6-12months) achievement of representative steady state conditions.

No interruption of cathodic protection current to the structure is required for monitoring.

Coupons may be placed directly over, at mid-line, or at the bottom line of the pipe being monitored. The unique parallel axis coupon configuration minimizes error in the IR drop measurements.

The measurements that can be made with the coupon test station after being allowed to receive CP current and polarize include the following:

- The 'on' potential of the structure and CP coupon.
- Instant 'off' potential of the polarized CP coupon.
- Potential of the native coupon (simulates native potential of the pipe).
- Depolarization of the polarized coupling by toggling switch to the "off" position.
- CP coupon current pick-up and discharge.

Custom test station lengths are available. Call for details.

DISTRIBUTED BY:
PROTECTION
Corrosion Protection Systems & Coatings, Inc.
ENGINEERING
2201 Harbor St, Unit C
Pittsburg, CA 94565
Tel: 800.878.8837
302 South 700 West
Pleasant Grove, UT 84062
Tel: 801.785.1546

www.corrosioncoatings.com info@corrosioncoatings.com

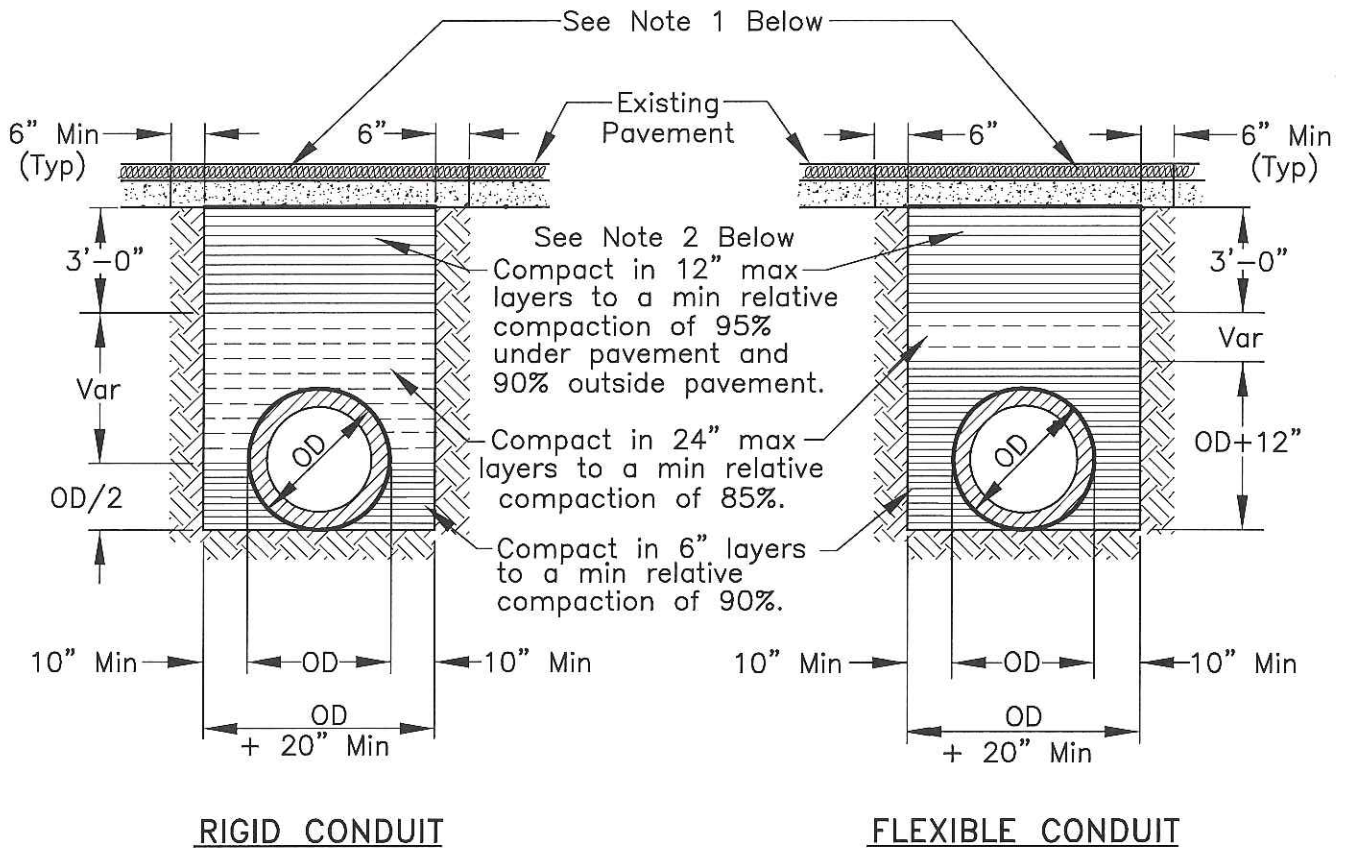

NOTES:

1. New pavement shall be 1" thicker than existing pavement, minimum of 0.25 Ft. New base shall be 1" thicker than existing base, min of 0.50 Ft.
2. Select native material or imported granular material as approved by the Director of Public Works. Backfill with materials equal to or better than the existing pavement and base in quality.
3. Relative compaction of materials shall be tested in accordance with the State of California, Dept. of Transportation Testing Manuals, test method No. California 216 or 231.
4. All existing pavement shall be neatly cut to line prior to trench excavation.
5. Jetting or ponding will be permitted within the street right-of-way with a 3 year bond, when approved by the Director of Public Works.
6. When shown by soil composition and compactability, ninety percent (90%) compaction may be used, when approved by the Director of Public Works.
7. Special bedding and backfill requirements may be shown on the plans or specified in the special provisions.

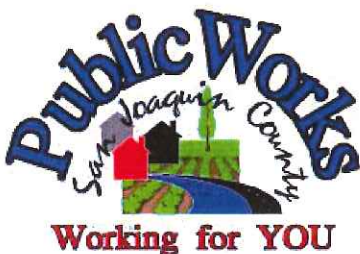

TYPICAL TRENCH BACKFILL

COUNTY OF SAN JOAQUIN
DEPARTMENT OF PUBLIC WORKS

Date: DEC 2014

Approved by:

Thomas M. Gill

No.	Revision	Description	Date

Std. Dwg. No.

R-29

GENERAL PROVISIONS

GOVERNING INSTALLATION OF SUBSURFACE STRUCTURES AND PIPELINES WITHIN COUNTY ROAD RIGHTS-OF-WAY

PUBLIC CONVENIENCE AND SAFETY:

- A. Before obstructing any private driveway entrance or County road traveled way with a trench, spoil bank, equipment or other barrier permitted for any prolonged period of time, the Permittee shall notify the known users of the respective thoroughfare(s) involved, and shall provide access for vehicular and pedestrian traffic to and from the road.
 - 1. Unless otherwise permitted, all work shall be conducted in such a manner that no less than one lane of the existing County road traveled way will be maintained open to public traffic during working hours in a smooth and safe riding condition(s). Two lanes shall be open after working hours.
 - 2. In cases where road closure is permitted, the permission to close the road will be granted under the condition that the Permittee notify the following persons and/or agencies of the time, the period of closure, and the detour route at least twenty-four (24) hours prior to said road closure.
 - a. The County of San Joaquin Public Works Department
 - b. The County of San Joaquin Sheriff's Office
 - c. The local postal service
 - d. The local fire district
 - e. The local school district
 - f. The local residents involved
- B. Should hazardous conditions relative to the installation operations warrant flagmen, as many capable flagmen as may be necessary shall be provided by the Permittee and stationed in advance of work to warn and direct traffic.
- C. Lights, signs and barricades shall be furnished, erected and maintained by the Permittee for the adequate warning and convenience of the public, with particular attention to be taken in this regard after dark.
- D. Any excess dirt and/or debris which might be a hazard to either automobile or pedestrian traffic, uncontrollable by lights, signs and barricades, shall be removed from the jobsite daily.

STRUCTURES:

- A. Walls of structures shall be such quality and strength that they will resist all pressures and will not crack or be deformed in such a way as to create a hazard or maintenance problem at any time. Therefore, the minimum structural requirements for concrete pipe placed under county road rights-of-way shall conform to the following American Association of State Highway and transportation Officials (AASHTO) designations.
 - 1. For concrete pipe up to and including thirty-three inches (33") inside diameter, extra strength concrete conforming to AASHTO Designation M 170M.
 - 2. For concrete pipe thirty-six inches (36") inside diameter and larger, reinforced concrete pipe conforming to AASHTO Designation M 170M Class III.
 - 3. Plastic pipe conforming to AASHTO Designation M294.
- B. All concrete pipe joints with County road rights-of-way shall be sealed against leakage and/or infiltration with rubber gasket in conformance with Section 65-1:06 of the California Standard Specifications, or with other methods as may be permitted under the Special Provisions.
- C. Cast-in-place concrete pipe, vitrified clay pipe, spiral welded steel pipe, or corrugated aluminum alloy pipe shall not be installed within the County road rights-of-way unless specifically so stated in the Special Provisions, and only under the conditions as provided.
- D. All structures to be buried within the County rights-of-way shall be set at such elevations as to allow minimum coverage of thirty inches (30") to the centerline of the roadways and twelve inches (12") at the bottoms of borrow ditches each side of the roadways. The depths of structures shall be established below a flat plane extending across the rights-of-way, no part of which shall extend above the elevations stated above; manholes, lampholes, valves, etc. not included. Future surface elevations shall be anticipated as nearly as possible and structure elevations shall be established for future adjustments accordingly.
- E. The County hereby reserves the right to specify in the Special Provisions the gage and surface treatment of any galvanized corrugated metal pipe that is to be installed.
- F. All longitudinal utility facilities are to be established (and dimensioned on sketches) from surveyed centerline of road right-of-way, not from right-of-way (border) lines.

REPAIRS OF THE COUNTY RIGHT-OF-WAY:

- A. All excavations shall be backfilled and compacted immediately after work therein has been completed.
- B. Trenched shall not be left open farther than 300 feet in advance of pipe laying operations, or 200 feet to the rear thereof, unless otherwise permitted by the Engineer.
- C. Unless otherwise permitted under the Special Provisions, backfill shall be placed and mechanically compacted in such a manner that the relative compaction throughout the entire fill within the County road right-of-way shall conform to the percentages of compaction as shown on the Trench detail.
- D. Backfill material shall be placed in horizontal uniform layers not to exceed in thickness, before compaction, 0.67 foot in the bedding region, one-foot where 90% compaction is required, and two-feet where 80% compaction is required.
- E. No portion of the excavation(s) shall be compacted by ponding or jetting unless a maintenance bond is provided.
- F. Gravel backfill material shall be utilized only where specifically so stated on the face of the permit. It shall be compacted by means of a high-frequency internal vibrator, the compactor to be a size and type approved by the Engineer. Points of compaction shall not be greater than 18" centers and to the full depth of the lift.
- G. All pavements, curbs, gutters, sidewalks, borrow ditches, pipes, head walls, road signs, trees, shrubbery, and/or other permanent road facilities impaired by or as a result of construction operations at the construction site(s) occupied by materials and/or equipment, shall be restored immediately upon backfilling of the excavation to the original grades and cross sections, and to a condition as good as, or better than existing prior to construction.
- H. All surfacing materials of roadways and driveway approaches cut or damaged by or as a result of construction operations, shall be replaced within ONE WEEK following the backfilling of excavation, weather permitting, with compacted layers of surfacing materials at least as thick as the existing, and no less than two inches (2") of asphalt concrete over six inches (6") of aggregate base, both as specified below.
 - 1. Asphalt Concrete: Combined mineral aggregate shall conform to the quality and gradation requirements for Type "B" one-half inch(1/2) maximum aggregate, coarse or medium gradation as specified in Section 39 of the California Standard Specifications. The bituminous binder to be mixed with mineral aggregate shall be paving asphalt having (Grade PG 64-10), unless otherwise directed by the Engineer. Placement of asphalt concrete surfacing shall conform to the applicable provisions of Section 39 of the California Standard Specifications.
 - 2. Aggregate Base: Combined mineral aggregates shall conform to the quality and the grading for three-quarter inch (3/4") maximum size aggregate Class 2 Aggregate Base specified in Section 26 of the California Standard Specifications.
- I. Before acceptance of repairs to the County road rights-of-way, all unsightly and detrimental dirt, dust and/or debris shall be removed and the construction areas left in a neat and presentable condition(s).
 - 1. If necessary, County road traveled way and driveway pavements shall be washed with water to remove dirt and dust.
 - 2. Driveway approaches and field entrance pavements damaged by equipment or spoil banks shall be repaired as directed by the Engineer.
- J. Upon request by the County, any settlement, sagging of surface, or cracking of pavement shall be repaired immediately by and at the sole expense of the Permittee for a period of one year following acceptance of the work.

SPECIAL PROVISIONS

Winter Weather Utility Work

1. **SUPERVISION:** The utility company (**permittee**) shall furnish full-time supervision of all work to insure compliance with the permit provision.
2. **START OF WORK:** No work within the County right-of-way shall be started until the utility company representative has made an evaluation of weather conditions and has determined the work can be accomplished under the provisions of the permit.
3. **CLEAN PAVEMENT:** Dirt and mud shall not be deposited on the pavement outside the area of work, and if inadvertently tracked onto the road travel way shall be removed immediately.
4. **DAILY RESTORATION:** Private driveways and road intersections shall be restored daily.
5. **WEATHER-TIGHT CONDITIONS:** All trenches shall be filled and compacted, ditches and other drainage facilities regarded and opened, and the entire work area restored to weather-tight condition prior to any rain.

GENERAL NOTES:

1. THIS DRAWING IS ISSUED FOR PERMIT. REFER TO CONTRACT DOCUMENTATION FOR ADDITIONAL CLARITY OF SCOPE OF WORK.
2. THIS DRAWING HAS BEEN CREATED BY REVIEW OF THE AS-BUILT DRAWINGS & RECORDS. ACCURACY IS DEPENDENT UPON THE SOURCE DOCUMENTS LISTED IN THE REFERENCE DOCUMENTS.
3. UTILITIES SHOWN ON DRAWING ARE APPROXIMATE BASED UPON REVIEW OF PG&E DIG SHEET, DIGS BASIS MEMO, & GIS. CONTRACTOR TO CALL USA TO HAVE LOCATION OF THESE FACILITIES MARKED & POTHOLE TO EXPOSE/VERIFY LOCATION.

CONSTRUCTION NOTES:

1. UNDERGROUND SERVICE ALERT : CALL 811 (1-800-227-2600) A MINIMUM OF 2 BUSINESS DAYS (NOT INCLUDING INITIAL DAY OF CONTACT) IN ADVANCE FOR THE MARKING OF UNDERGROUND UTILITIES, INCLUDING ALL NON-UTILITIES BEFORE YOU DIG, GRADE, OR EXCAVATE.
2. UTILITY NOTES:
 - A. DIMENSIONS SHOWN ON THESE DRAWINGS ARE BASED ON THE BEST AVAILABLE INFORMATION FROM SEVERAL SOURCES, & SHALL BE VERIFIED IN THE FIELD BY CONSTRUCTION PERSONNEL PRIOR TO EXCAVATION.
 - B. THE INFORMATION SHOWN ON THESE DRAWINGS CONCERNING TYPE & LOCATION OF UNDERGROUND UTILITIES, PROPERTY LINES, & OTHER SUBSTRUCTURES IS NOT GUARANTEED TO BE ACCURATE OR ALL-INCLUSIVE, UNLESS OTHERWISE NOTED. CONSTRUCTION PERSONNEL ARE RESPONSIBLE FOR MAKING ALL DETERMINATIONS AS TO THE TYPE & LOCATION OF UNDERGROUND UTILITIES & OTHER SUBSTRUCTURES AS NECESSARY TO AVOID DAMAGE OR ENCROACHMENTS.
 - C. PROSPECTING IS REQUIRED AHEAD OF WORK.
 - D. ALL EXCAVATIONS WITHIN EXISTING STATIONS SHALL BE HAND DUG OR EXCAVATED USING SOFT DIG METHODS (e.g. VACUUM EXCAVATIONS OR SIMILAR).
3. COATING REMOVAL:

BEFORE REMOVING THE PIPE COATING ON PRE-1972 PIPE (DOES NOT INCLUDE PLASTIC TAPE OR FUSION BONDED EPOXY COATINGS) THE FOLLOWING STEPS SHALL BE TAKEN:

 - A. FOR ALL NON-EMERGENCY WORK, PRE-1972 PIPE WRAP MUST BE EVALUATED TO DETERMINE IF IT CONTAINS ASBESTOS PRIOR TO REMOVAL.
 - B. FOR EMERGENCY WORK ON PRE-1972 PIPE, ASSUME THE WRAP CONTAINS > 1% ASBESTOS UNTIL THE WRAP CAN BE TESTED.
 - C. OBTAIN SAMPLES OF THE WRAP, & HAVE SAMPLES TESTED FOR ASBESTOS IN ACCORDANCE WITH WP 4711-01.
 - D. TEST RESULTS ARE TO BE INCLUDED WITH THE FINAL JOB PACKAGE.
 - E. FOLLOW PROCEDURE IN WP 4711-01 FOR REMOVAL OF PIPE WRAP.

CONSTRUCTION NOTES CONTINUED:

4. RESTORATION & CLEAN UP:
 - A. RESTORATION OF PUBLIC STREETS, SIDEWALKS, CURBS, ETC. ABOVE PIPE BEDDING SHALL BE IN ACCORDANCE WITH THE LATEST CITY, COUNTY, OR AGENCY STANDARDS.
 - B. WHEREVER THERE ARE ROW CROPS, THE TOPSOIL SHALL BE REMOVED TO A DEPTH OF 12" & STORED ON SITE. UPON COMPLETION OF CONSTRUCTION, THE TOPSOIL SHALL BE RESTORED. TAKE CARE TO PREVENT MIXING OF TOPSOIL & SUBSOIL.
5. WELDING REQUIREMENTS:
 - A. INSTALL TEST STATIONS WITH THERMITE WELD CONNECTION IN ACCORDANCE WITH GAS T & D CORROSION CONTROL MANUAL O-10, O-10.1, & O-10.2.
6. PAINTING & COATING REQUIREMENTS:
 - A. ALL EXPOSED PIPE & FITTINGS ARE TO BE PAINTED IN ACCORDANCE WITH GAS STANDARD E-30. ALL COATING ON BURIED PIPE & FITTINGS ARE TO BE APPLIED IN ACCORDANCE WITH GAS STANDARD E-35.
 - B. FOR COATING SELECTIONS ON BURIED PIPE, SEE DIRECT BURIAL COATING SELECTIONS TABLE.
7. DOCUMENTATION OF INSPECTION OF EXISTING PIPELINE:

WHENEVER EXISTING BURIED GAS FACILITIES ARE EXCAVATED DURING ENGINEERING OR DURING CONSTRUCTION, AN A-FORM (TD-4110P-03-F01) SHALL BE COMPLETED FOR THE GENERAL INSPECTION. THIS ALSO APPLIES TO GAS FACILITIES BEING DEACTIVATED. THE COMPLETED A-FORM SHALL BE SUBMITTED WITH THE FINAL JOB PACKAGE.
8. COPIES OF REFERENCE DRAWINGS ARE AVAILABLE TO FIELD PERSONNEL (PG&E, INSPECTION OR CONTRACTOR) IF REQUESTED. CONTACT THE CONTRACT ENGINEER IDENTIFIED IN CONTACTS TO OBTAIN COPIES OF REFERENCE DRAWINGS.

SEQUENCE OF OPERATIONS:

1. DIG 4' X 4' BELL HOLE AT LOCATION AND EXPOSE PIPELINE.
2. INSTALL ABOVE OR BELOW GROUND CTS DEPENDING ON EXISTING TRAFFIC CONDITIONS.
3. BACKFILL & COMPACT EXCAVATION PER PERMIT STANDARDS.
4. RESTORE PROJECT SITE.

CONTACT INFORMATION:

PROJECT MANAGER	----	ARTURO AHUMADA	(925) 404-4064
PROJECT ENGINEER	----	SAMUEL THOMAS	(707) 580-2608
PIPELINE ENGINEER	----	CARLOS CABRERA	(925) 789-0509
LAND PLANNER	----	SARAH CARTER	(925) 786-2149
CULTURAL MONITOR	----	STARLA LANE	(925) 328-5033
BIOLOGIST	----	BEN HART	(559) 770-0027

	ISSUED FOR REVIEW	MV.	09 APR 18

LEGEND:
 EXISTING PIPELINE
 UID# - SHEET#



QUANTA ENERGY SERVICES, LLC
 5145 INDUSTRIAL WAY, BENICIA, CA 94510

CTS INSTALLATIONS
 ID: C-760
 YOSEMITE DIVISION
 CALIFORNIA

PAPER	11"x17"	ORDER: 31205564
SCALE	N/A	DWG. NO. REV.
DWN. BY	MVJ	C-760 2
DATE	09 Apr 2018	SHEET 7 OF 23
APP.	XXX	

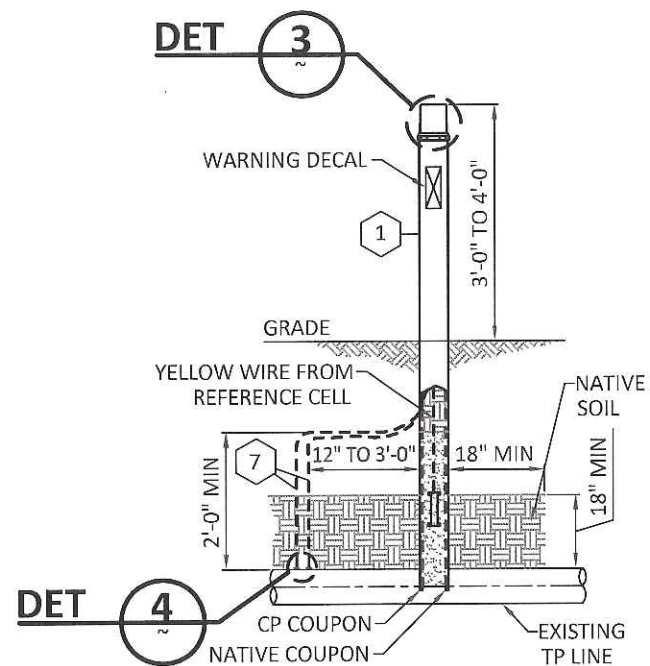

NOTE:
INSTALL REFERENCE ELECTRODE WITHIN 12" FROM THE BOTTOM OF THE TUBE. FILL TUBING WITH CASING MUD TO AT LEAST 12" ABOVE REFERENCE ELECTRODE. THE REMAINDER OF THE TUBE CAN BE FILLED WITH NATIVE SOIL.

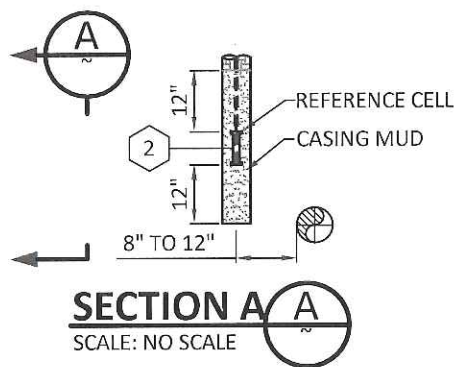

DETAIL 1 COUPON TEST STATION ABOVE GROUND
SCALE: NO SCALE SHTS 10-23
CCV O-10.2

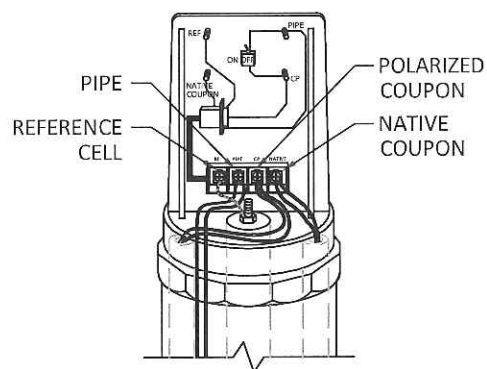

NOTE: 7 WIRES TO UNIT NPC (BLACK X2), WIRE PC (WHITE X2), WIRE REF CELL (YELLOW), PIPE #10 (BLACK X2) GAUGE SOLID WIRES

DETAIL 3 COUPON TEST STATION HEAD
SCALE: NO SCALE CCV O-10.2

- NOTES:
- COUPONS SHALL BE INSTALLED TO THE DEPTH OF THE CENTERLINE OF THE PIPELINE.
 - INSTALL COUPONS PARALLEL TO PIPE AT A DISTANCE OF 8" TO 12". COUPONS MUST BE INSTALLED IN NATIVE SOIL WITHIN 18" OF ELECTRODE. TAMP NATIVE AND ADD IMPORT TO ACHIEVE A MINIMUM 95% COMPACTION.
 - IN ORDER TO OFFSET THE COUPON TEST STATION, THE CONDUIT HAS TO BE CUT AND THE TEST LEADS SPLICED AND EXTENDED TO THE LOCATION WHERE THE ABOVE GROUND TEST STATION WILL BE LOCATED.
 - ABOVE GROUND UNIT SHALL BE LOCATED IN AN AREA SAFE FROM PEDESTRIAN AND VEHICLE TRAFFIC.
 - USE CTS OFFSET KIT TO SPLICE 2-14 AWG WHITE WIRES FROM THE NATIVE COUPON WITH DRYCONN LUGS WITH SINGLE 14 AWG WHITE WIRE INCLUDED IN THE CTS OFFSET KIT AND EXTEND THROUGH THE CONDUIT OFFSET TO THE ABOVE GROUND TEST HEAD.
 - USE CTS OFFSET KIT TO SPLICE 2-14 AWG BLACK WIRES FROM THE CP COUPON WITH DRYCONN LUGS WITH SINGLE 14 AWG BLACK WIRE INCLUDED IN THE CTS OFFSET KIT AND EXTEND THROUGH THE CONDUIT OFFSET TO THE ABOVE GROUND TEST HEAD.

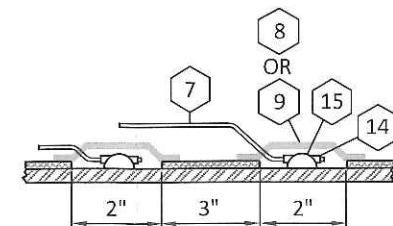

DETAIL 4 ATTACHING THE WIRES TO THE GAS MAIN
SCALE: NO SCALE (CCV O-10) FIGURE 1

△	ISSUED FOR REVIEW	MV.	09 APR 18
△			
△			
△			

LEGEND:
— EXISTING PIPELINE
○ UID# - SHEET#

- INTERSTATE
- CA HIGHWAY
- US HIGHWAY

QUANTA ENERGY SERVICES, LLC
5145 INDUSTRIAL WAY, BENICIA, CA 94510



CTS INSTALLATIONS
ID: C-760
YOSEMITE DIVISION

CALIFORNIA

PAPER	11"x17"
SCALE	N/A
DWN. BY	MVJ
DATE	09 Apr 2018
APP.	XXX

ORDER: 31205564
DWG. NO. REV.
C-760 2
SHEET 8 OF 23

CTS INSTALLATION BOM

COMPONENT	DESCRIPTION	CODE	GS&S	NOTES
1	COUPON TEST STATION (3" OD X 10")	M560691	GS&S O-10.3	
2	ELECTRODE REFERENCE GMC STAPERM CUCUS04 (WITH NON-ORGANIC CASING MUD)	M241269	GS&S O-10.2	
3	BODY, CONCRETE, VALVE FRAME, CHRISTY #G05, W/O COVER, 10-3/8" DIA X 12" HIGH	M043271	GS&S K-40	
4	COVER, VALVE, CAST IRON, YELLOW, CHRISTY #G05CY, FULL TRAFFIC, 11-1/8", TRAFFIC	M446213	GS&S K-40	
5	2" PVC CONDUIT, SCHEDULE 40, 10' LENGTHS	M360380	GS&S O-13.2	
6	CONDUIT, 3" PVC, SCHEDULE 80, WITH TWO GAS PIPELINE WARNING DECALS	M016071	GS&S O-10.1	
7	WIRE, ELECTRICAL, INSULATED, COPPER, 10 AWG, 600 V, 47 MIL PVC, SOLID 1 CONDUCTOR, BLACK	M294991	CCV O-16	
8	ROYSTON 4" X 4" HANDY CAP	M562324	GS&S O-10	
9	ROYSTON 5" X 5" HANDY CAP	M561457	GS&S O-10	
10	LIQUID ADHESIVE: ROYSTON ROYBOND 747, 16 OUNCE SPRAY CAN, 12 PER CARTON	M130850	GS&S O-10	
11	STEEL PIPE 3/4" TO 3-1/2" DIA: CADWELD MOLD - CAHAA -1LA (P/N 03-11080)	M206487	GS&S O-10	
12	STEEL PIPE 4" TO 5" DIA: CADWELD MOLD - CAHAA-1LB (P/N 03-11090)	M206488	GS&S O-10	
13	STEEL PIPE 6" OR LARGER DIA: CADWELD MOLD - CAHAA-1L (P/N 03-11070)	M206489	GS&S O-10	
14	SLEEVE, COPPER, THERMOWELD A200 OR EQUIVALENT	M303755	GS&S O-10	
15	CARTRIDGE, CADWELD CA-15, OR THERMOWELD 15P, 15-GRAM	M159260	GS&S O-10	

- NOTES:**
- COUPONS SHALL BE INSTALLED TO THE DEPTH OF THE CENTERLINE OF THE PIPELINE.
 - INSTALL COUPONS PARALLEL TO PIPE AT A DISTANCE OF 8" TO 12". COUPONS MUST BE INSTALLED IN NATIVE SOIL WITHIN 18" OF ELECTRODE. TAMP NATIVE AND ADD IMPORT TO ACHIEVE A MINIMUM 95% COMPACTION.
 - IN ORDER TO OFFSET THE COUPON TEST STATION, THE CONDUIT HAS TO BE CUT AND THE TEST LEADS SPLICED AND EXTENDED TO THE LOCATION WHERE THE ABOVE GROUND TEST STATION WILL BE LOCATED.
 - ABOVE GROUND UNIT SHALL BE LOCATED IN AN AREA SAFE FROM PEDESTRIAN AND VEHICLE TRAFFIC.
 - USE CTS OFFSET KIT TO SPLICE 2-14 AWG WHITE WIRES FROM THE NATIVE COUPON WITH DRYCONN LUGS WITH SINGLE 14 AWG WHITE WIRE INCLUDED IN THE CTS OFFSET KIT AND EXTEND THROUGH THE CONDUIT OFFSET TO THE ABOVE GROUND TEST HEAD.
 - USE CTS OFFSET KIT TO SPLICE 2-14 AWG BLACK WIRES FROM THE CP COUPON WITH DRYCONN LUGS WITH SINGLE 14 AWG BLACK WIRE INCLUDED IN THE CTS OFFSET KIT AND EXTEND THROUGH THE CONDUIT OFFSET TO THE ABOVE GROUND TEST HEAD.

	ISSUED FOR REVIEW	MVJ	09 APR 18

LEGEND:
 EXISTING PIPELINE
 UID# - SHEET#



QUANTA ENERGY SERVICES, LLC
 5145 INDUSTRIAL WAY, BENICIA, CA 94510

CTS INSTALLATIONS
 ID: C-760
 YOSEMITE DIVISION
 CALIFORNIA

PAPER	11"x17"	ORDER: 31205564
SCALE	N/A	DWG. NO. REV.
DWN. BY	MVJ	C-760 2
DATE	09 Apr 2018	SHEET 9 OF 23
APP.	XXX	

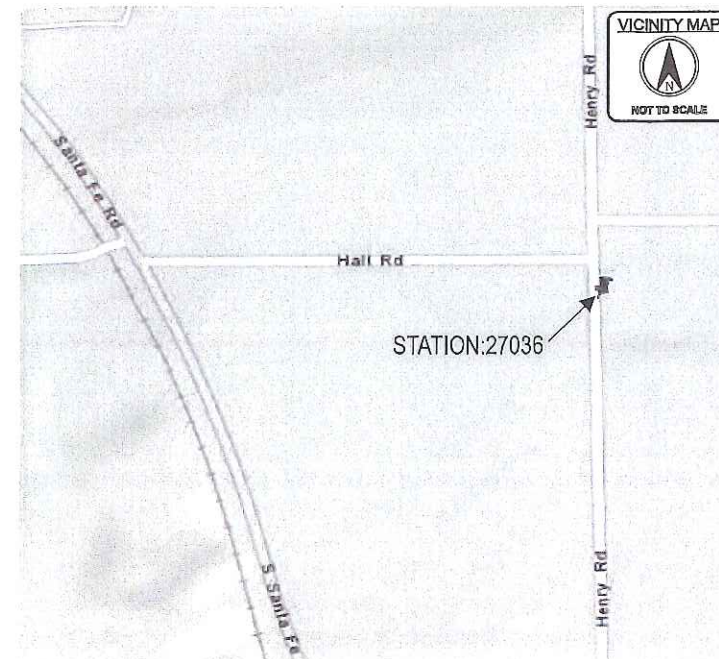

TYPICAL LANE CLOSURE ON TWO-WAY ROAD USING FLAGGERS

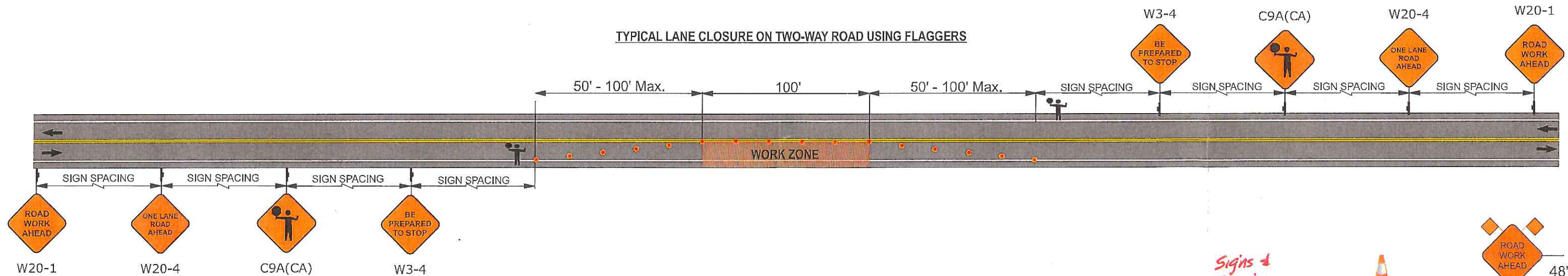

Signs & Spacing Per MUTCD Standards



LEGEND



28" TRAFFIC CONE
 TEMPORARY SIGN STAND (Showing facing right)
 DIRECTION OF TRAFFIC
 FLAGGER STATION
 WORK ZONE

ROAD TYPE	DISTANCE BETWEEN SIGNS		
	A	B	C
URBAN (LOW SPEED) - 25 MPH OR LESS	100 FEET	100 FEET	100 FEET
URBAN (HIGH SPEED) - MORE THAN 25 MPH TO 40 MPH	250 FEET	250 FEET	250 FEET
URBAN (HIGH SPEED) - MORE THAN 40 MPH	350 FEET	350 FEET	350 FEET
RURAL	500 FEET	500 FEET	500 FEET
EXPRESSWAY / FREEWAY	1,000 FEET	1,500 FEET	2,640 FEET

TRAFFIC CONTROL GENERAL NOTES:

- All traffic control devices shall conform to the latest edition on California Manual on Uniform Traffic Control Devices (MUTCD) and the Standard Specifications for Public Works.
- High-Level Warning Devices (Flag Trees) Shall consist of minimum of two flags. The distance from the roadway to the bottom of the flag shall be not less than 8 feet. The flag shall be minimum 16 inches and orange or fluorescent red-orange in color.
- All workers shall be equipped with a reflective vest. All Flaggers shall also be equipped with a hard hat, Stop/Slow paddle, Two-way radio, and shall be trained in the proper fundamentals of flagging traffic.
- NO PARKING signs shall be placed 72 hours prior to set up. Signs shall be posted every 20 linear feet of occupied space with at least one sign at each end of occupied space.
- The buffer space should be extended so that the two-way traffic taper is placed before a horizontal (or crest vertical) curve to provide adequate sight distance for the flagger and a queue of stopped vehicles.
- Access to residents and businesses shall be maintained at all times. Access to be determined in field by existing conditions. Maintain safe pedestrian route. Maintain 12 feet lanes unless otherwise noted.
- The contractor shall take all necessary precautions to allow emergency vehicles to pass through the construction zones without any delays.
- During the hours of darkness the flagger-station and flagger shall be illuminated and clearly visible to approaching traffic. The illumination footprint of light on ground shall be 20 feet in diameter.
- Engineer or his representative has the authority to initiate field changes to assure public safety.

STATEWIDE
 TRAFFIC SAFETY & SIGNS

130 Grobric Ct
 Fairfield, CA 94534
 Ph: 707-864-9952

PREPARED BY: Josh DeHart Email: jdehart@stssi.com
 ATSSA CERT# 00138360

PRIME CONTRACTOR:
 Underground Construction Company, Inc.
 5145 Industrial Way
 Benicia, CA 94510
 Ph: (707) 764-8800

CONTACT: Denisa Salva (707) 741-1761

PROJECT No.	C-760	DRAWING No.	18-062-1	DATE:	April 13, 2018	1	7
-------------	-------	-------------	----------	-------	----------------	---	---